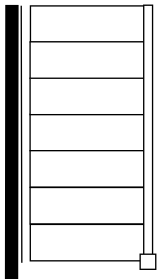
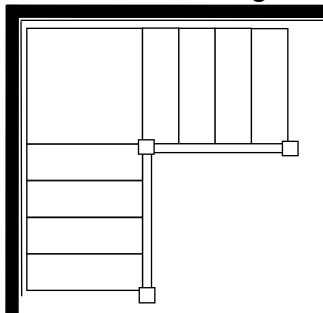
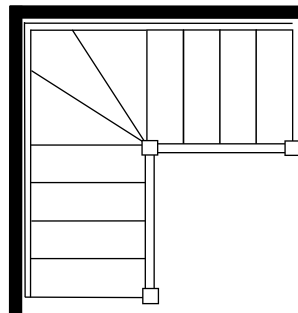
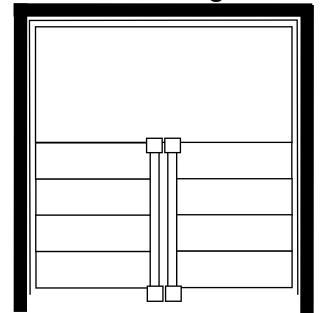
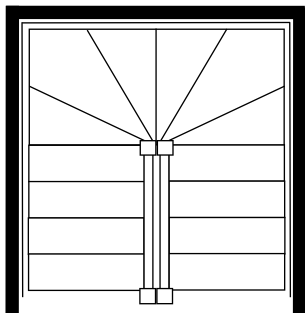
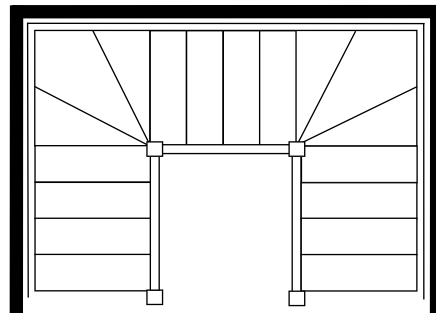
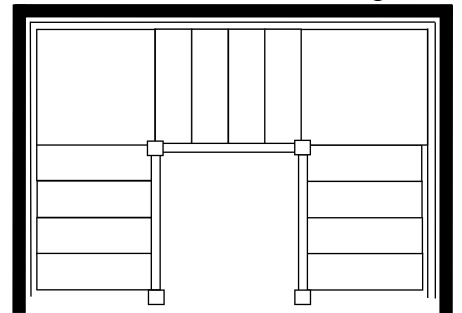

Create your own staircase in 6 easy steps . . .

1. Customer Details

Name	
Address	
Post Code	email
Phone	Mobile

2. Choose your flight

 Straight

 Quarter Landing

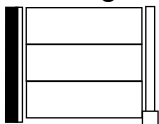
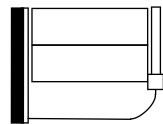
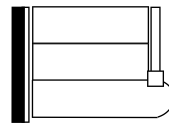
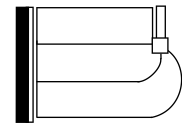
 Quarter Winder

 Half Landing

 180 Turn with Winder

 Double Quarter Winder

 Double Quarter Landing

3. Select a bottom step feature

 Straight

 Bullnose

 Curtail

 Bullnose & Curtail

4. Measure up & Specify

Finished floor to finished floor (A) = _____ mm

Total going (B) = _____ mm

Well length & width (C) = _____ mm x _____ mm

Joist, floor 2 ceiling total depth (D) = _____ mm

Overall stair width = _____ mm

Spindles & Newels: Square Turned or Fluted

String: Cut String or Straight String

Timber: OAK or other _____

Supply: Supply Only or Fully Fitted

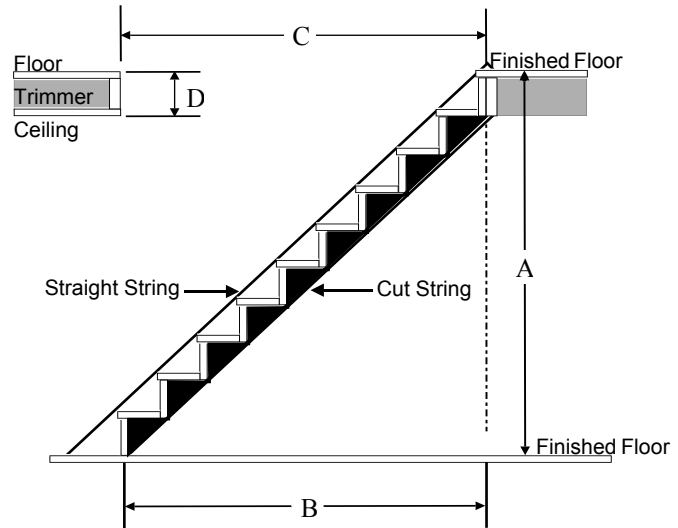

5. Draw your staircase

For example . . .

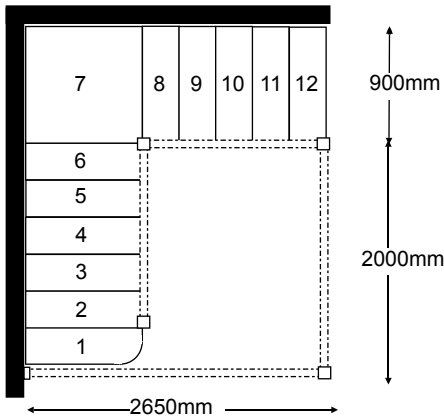

Staircases available in:

- English Ash
- American Ash
- European Oak
- White Oak
- Cherry
- Hemlock
- American Black Walnut
- Pine
- Sapele
- Canadian Hard Maple
- Zebra Maple
- Beech
- Teak
- Raintree
- Mango

Indicate any apertures, doors, windows etc that encroach on the staircase as these can be subject to building regulations

6. Fax or Post both completed pages to :

Timber Natural Limited
211 Ratcliffe Road, Sileby, Leicestershire LE12 7PY

or

Fax 0870 787 9396